

1 1/2" INSIDE GLAZED WINDOW SYSTEM

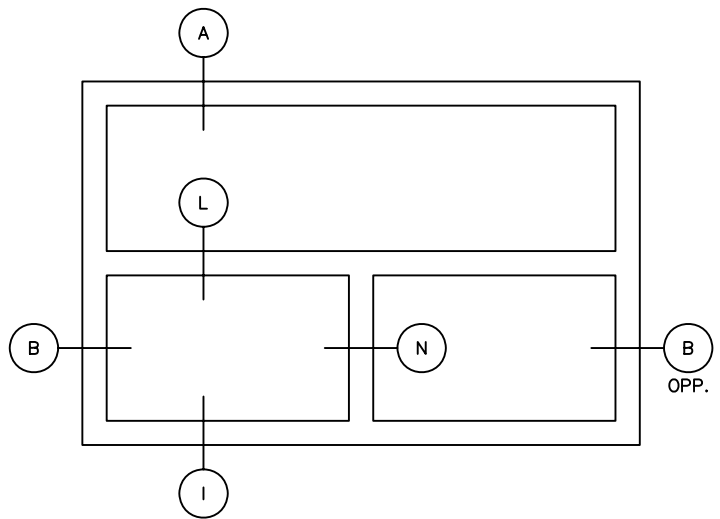

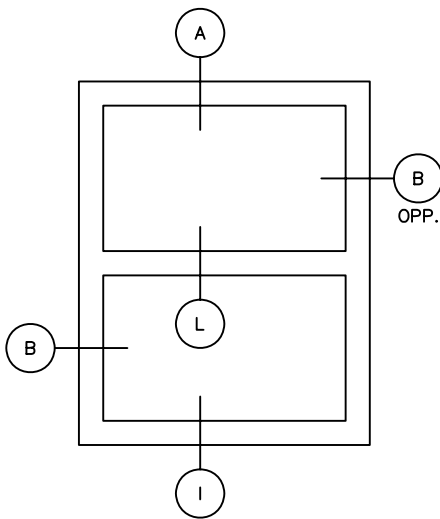

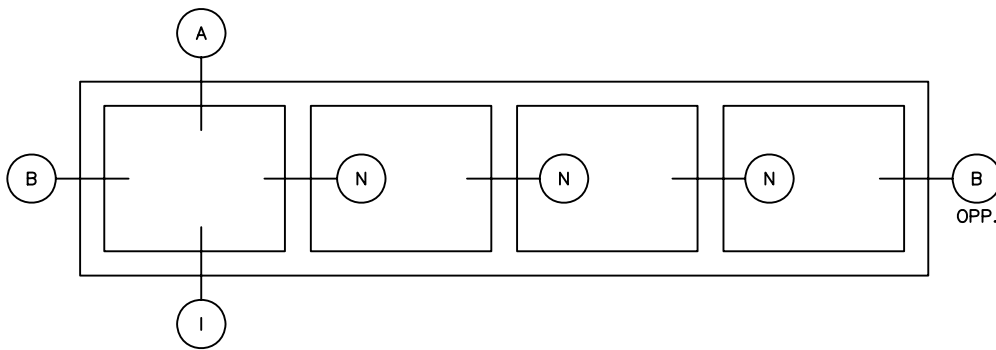

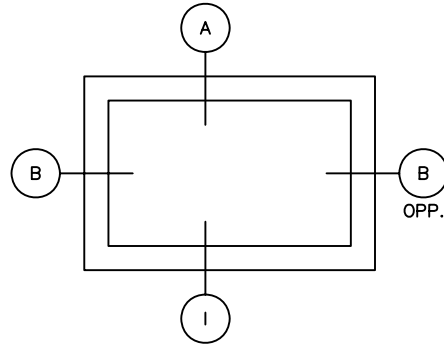
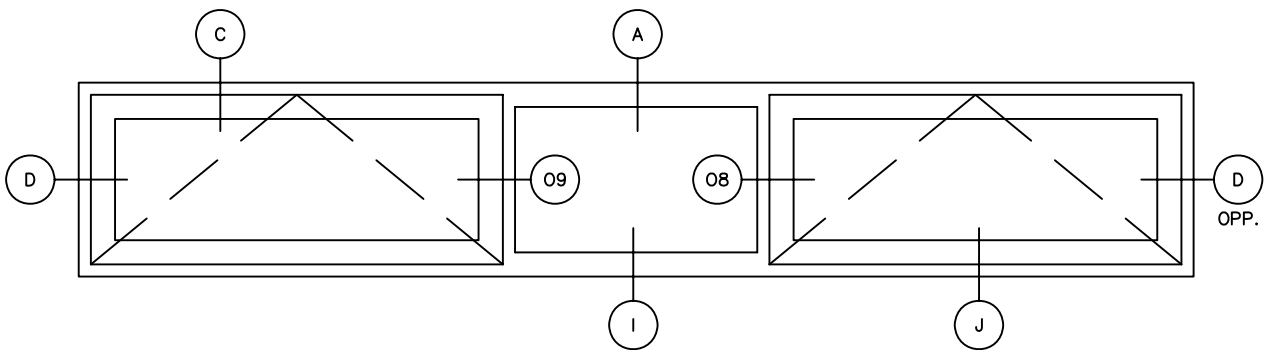
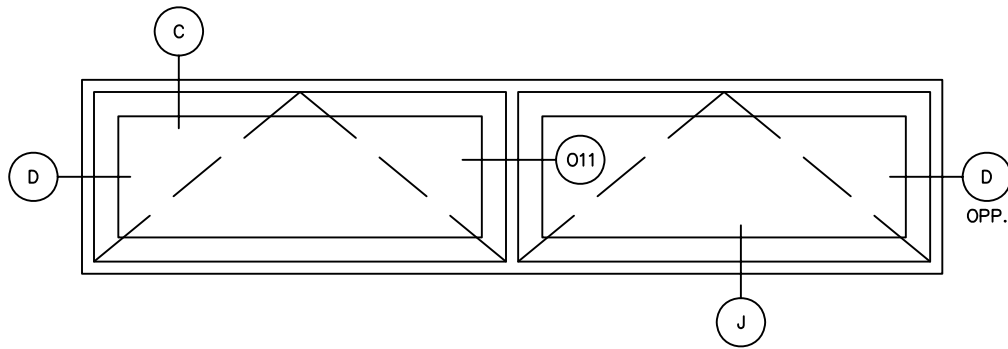
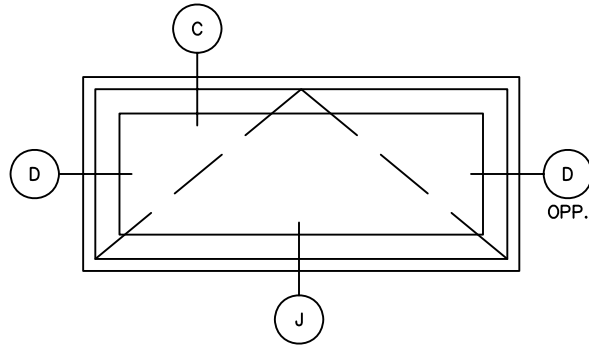
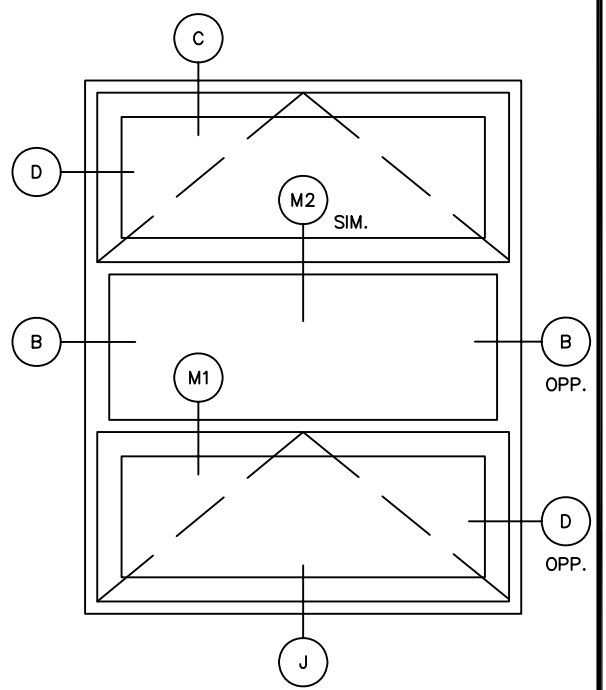
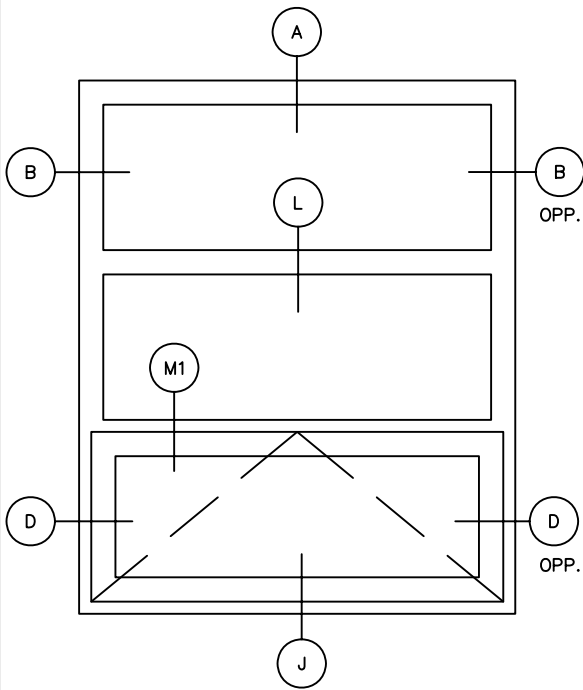
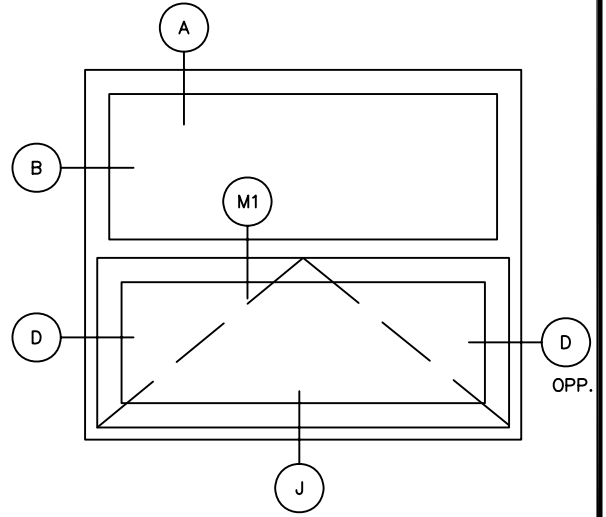
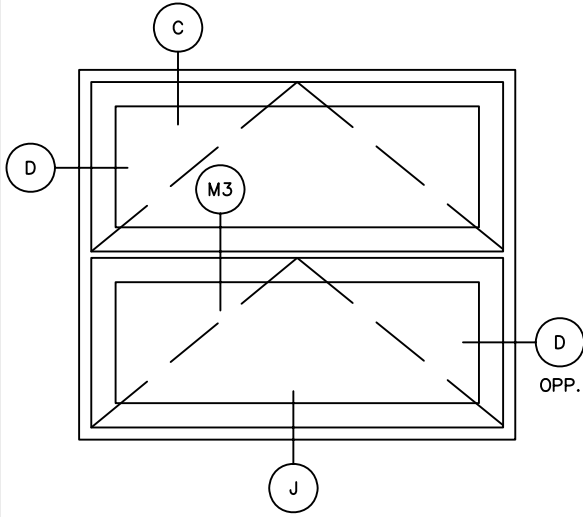
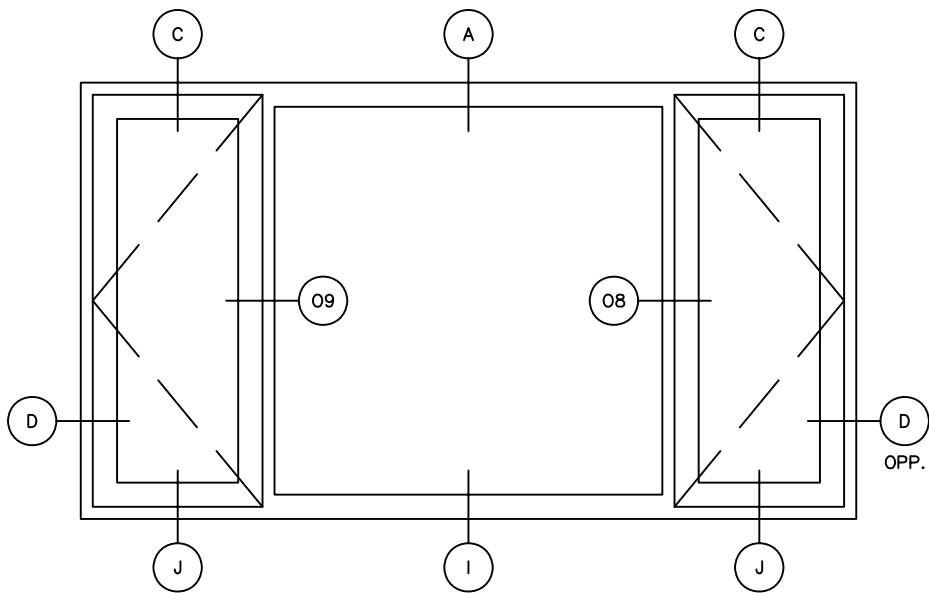
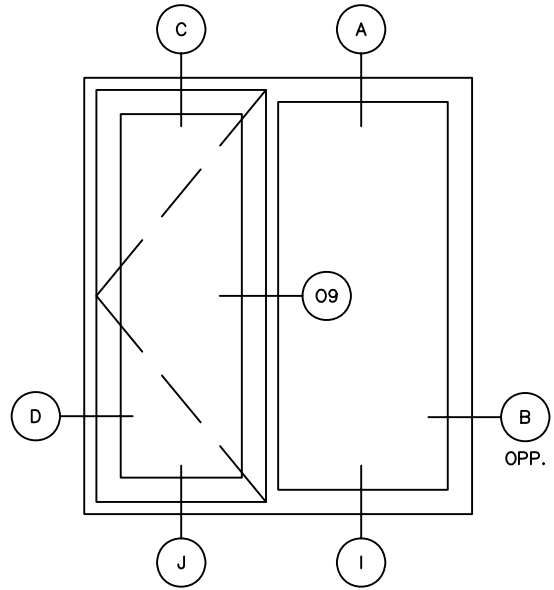
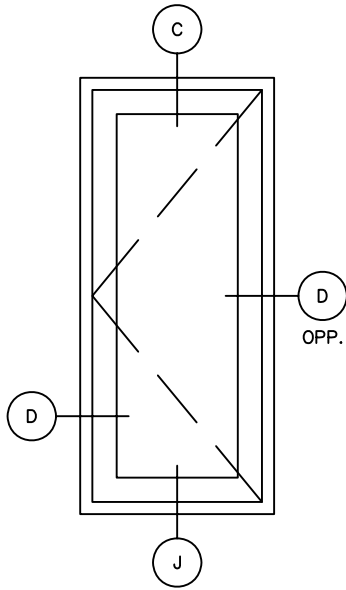

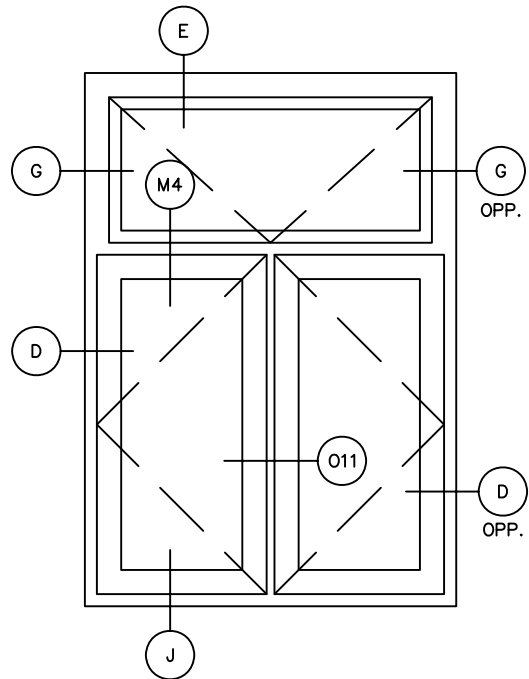
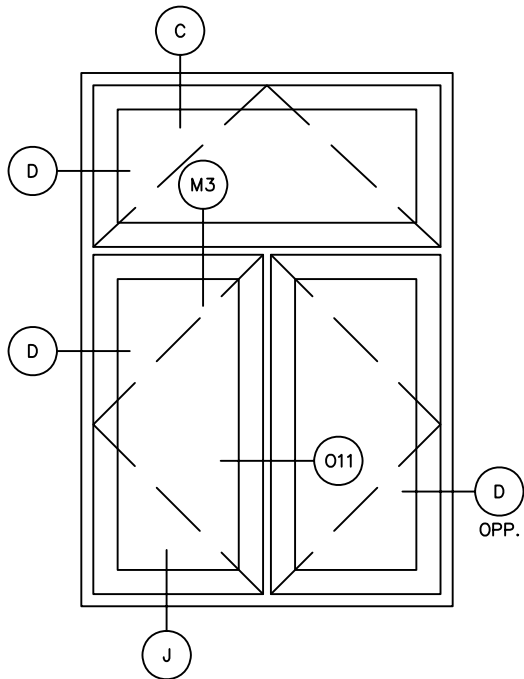
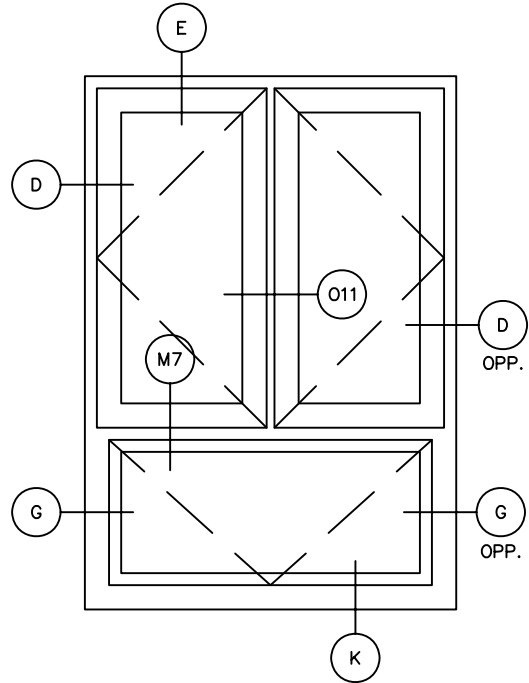
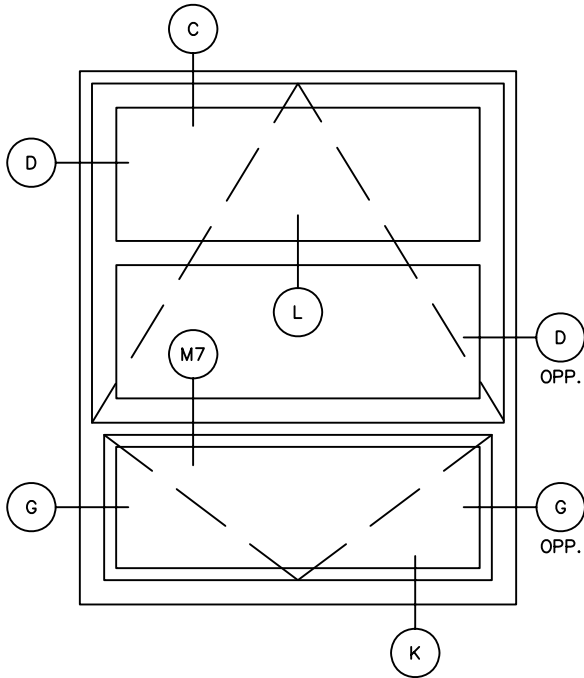

A HEAD-FIXED

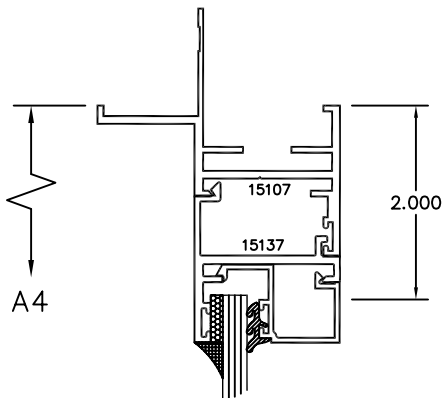
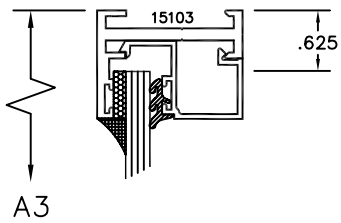
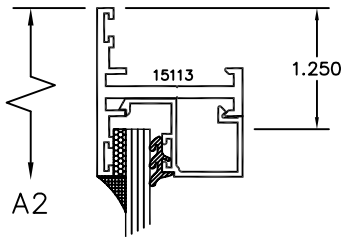
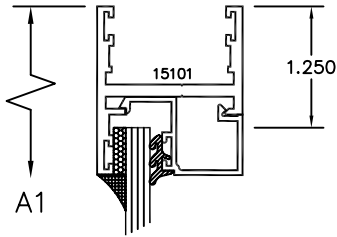

B JAMB-FIXED

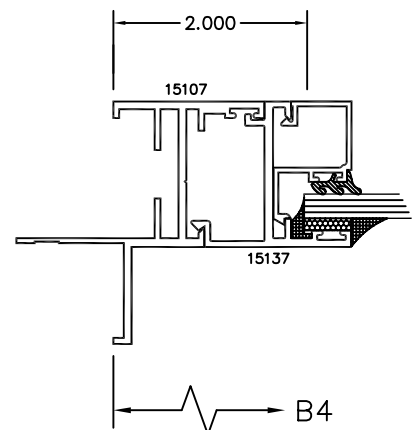
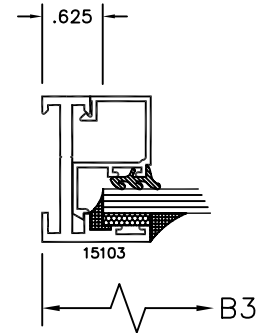
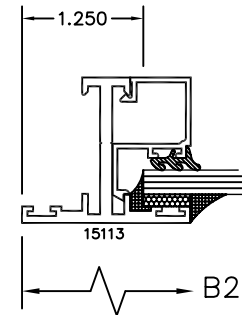
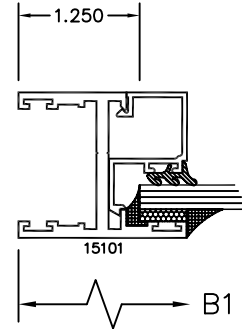

(C) HEAD-PROJECT OUT

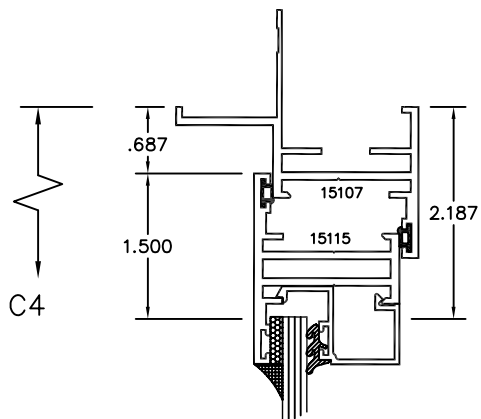
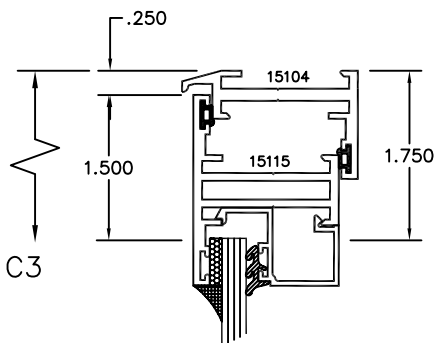
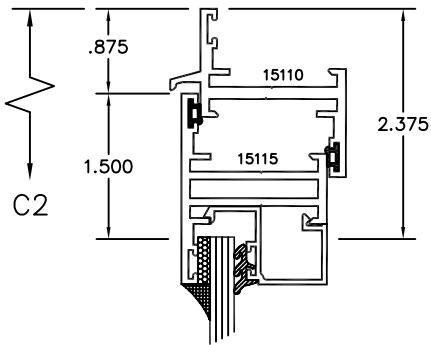
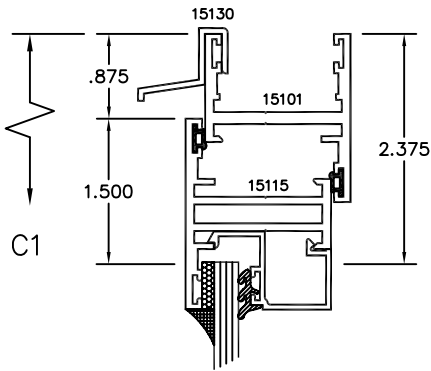

(D) JAMB-PROJECT OUT

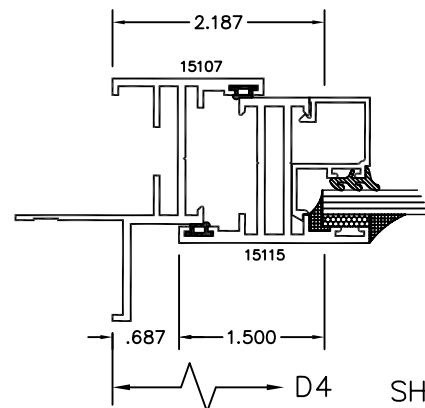
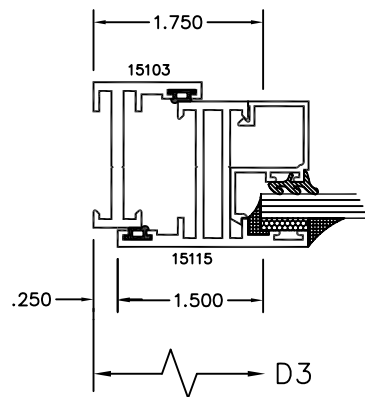
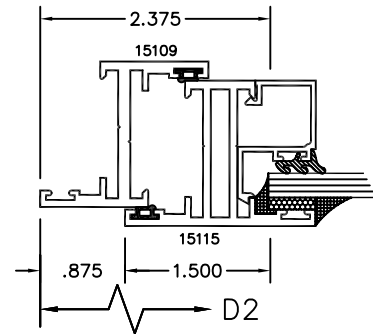
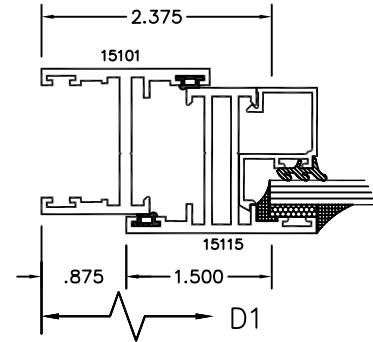

E HEAD-PROJECT IN

F HEAD-PROJECT IN
W/SCAB BAR

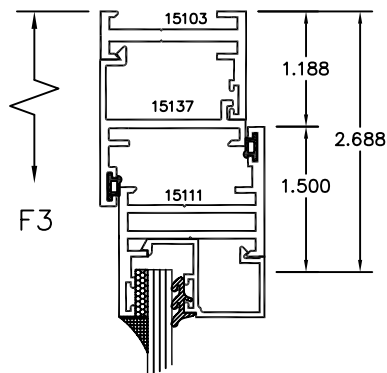
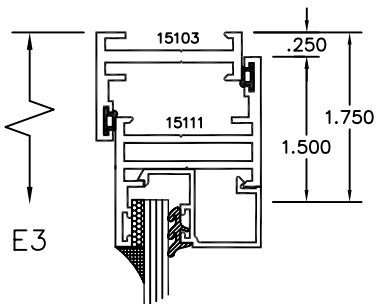
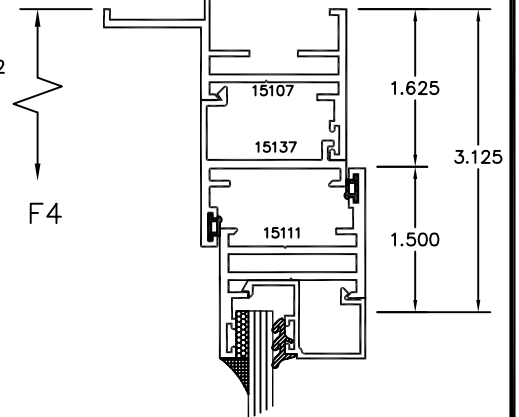
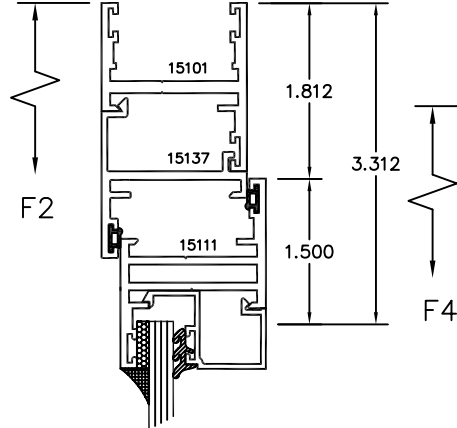
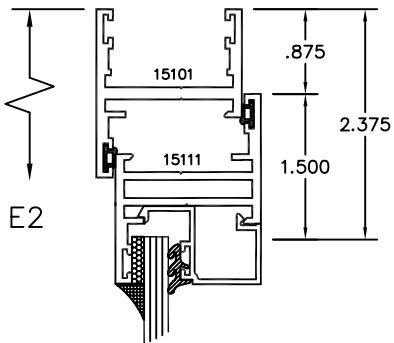
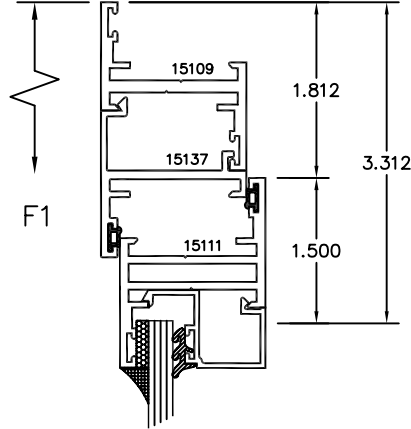
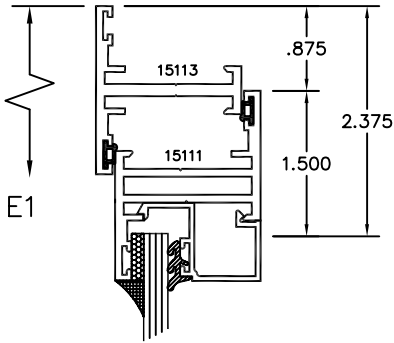

G JAMB-PROJECT IN

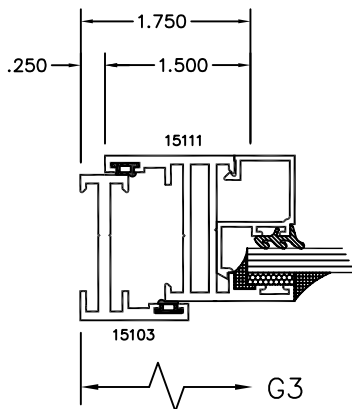
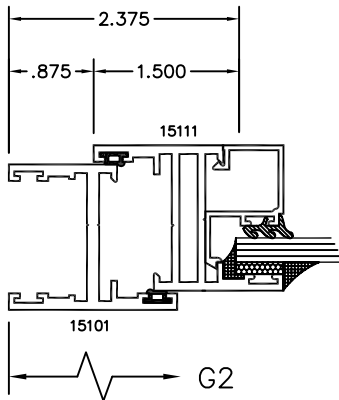
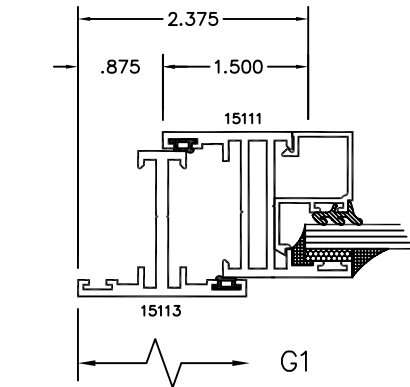

H JAMB-PROJECT IN
W/SCAB BAR

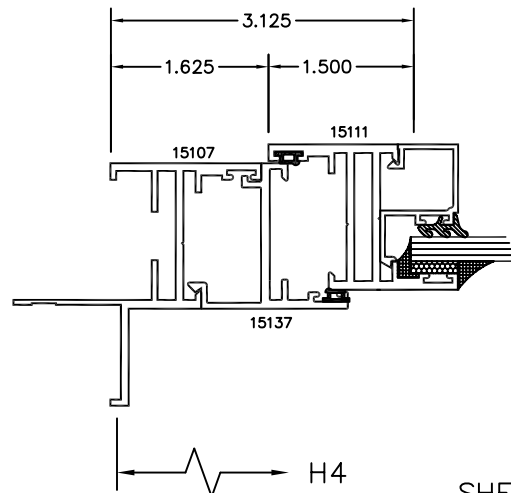
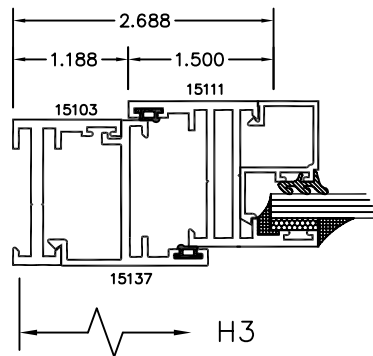
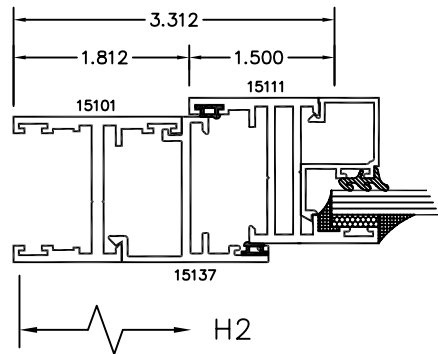
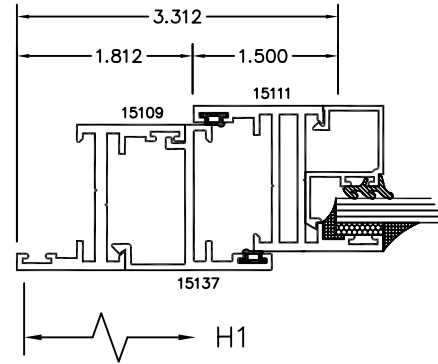

I SILL-FIXED

J SILL-PROJECT OUT

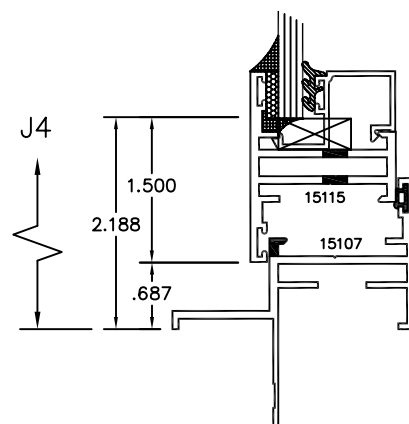
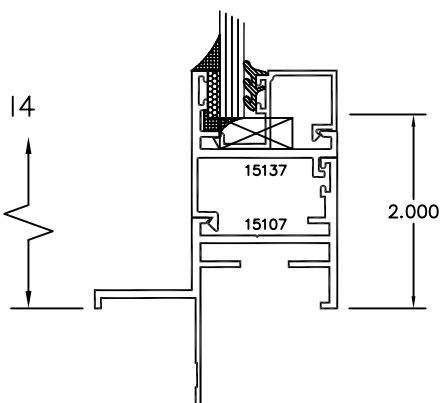
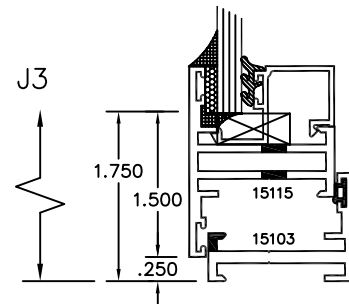
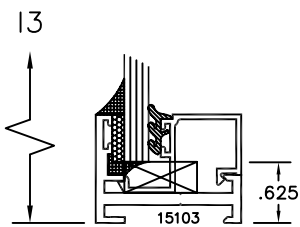
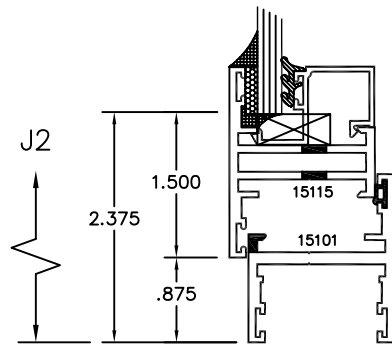
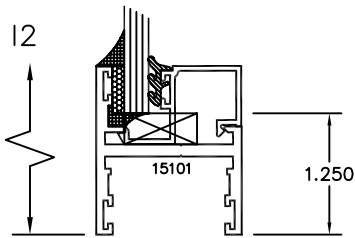
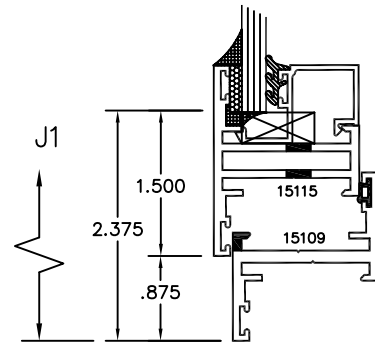
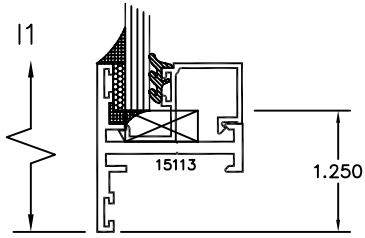

(K) SILL-PROJECT IN

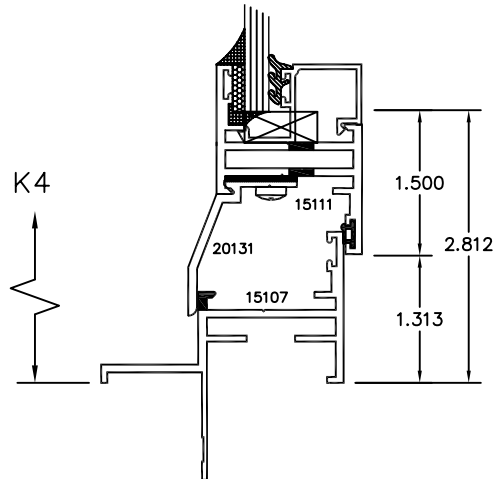
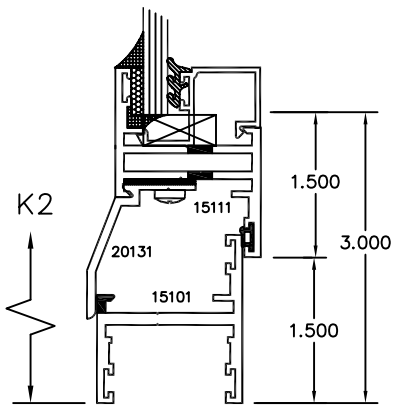
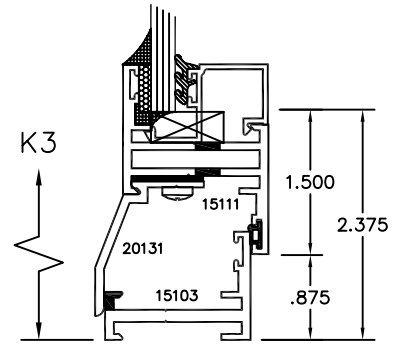
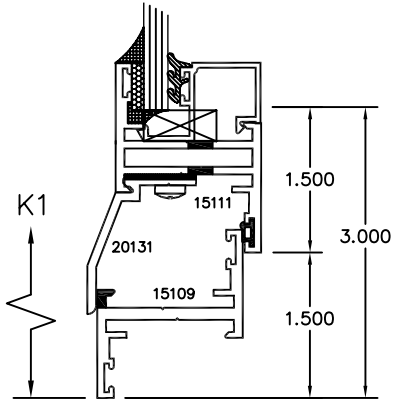

(L) HORIZONTAL INTERMEDIATE

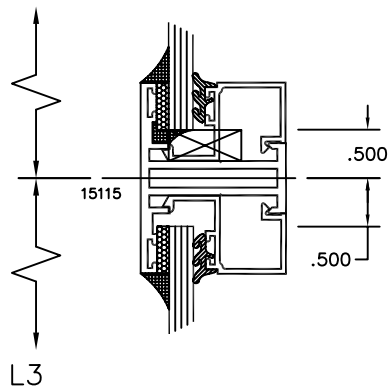

M HORIZONTAL INTERMEDIATES
PROJECT IN, PROJECT OUT
& COMBINATION

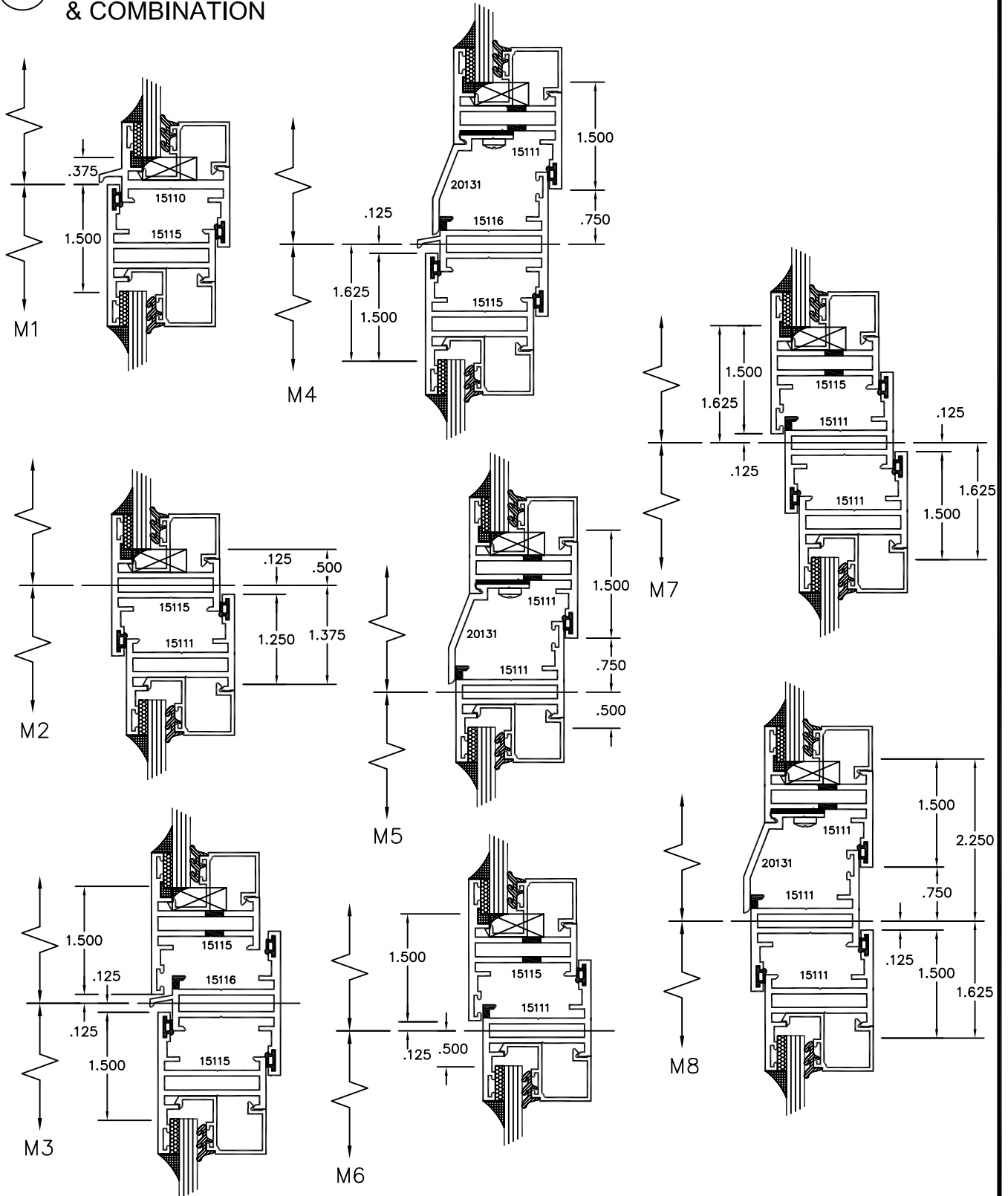

(N) VERTICAL INTERMEDIATE

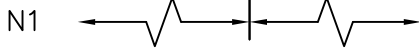
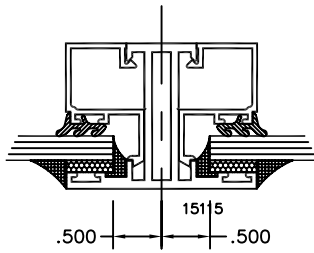

(O) VERTICAL INTERMEDIATES
PROJECT IN, PROJECT OUT
& COMBINATION

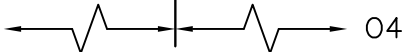
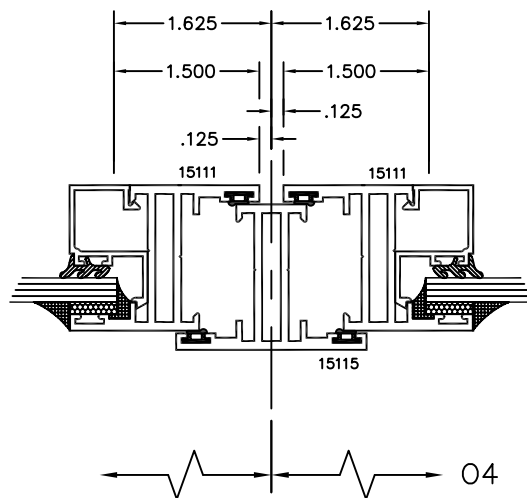
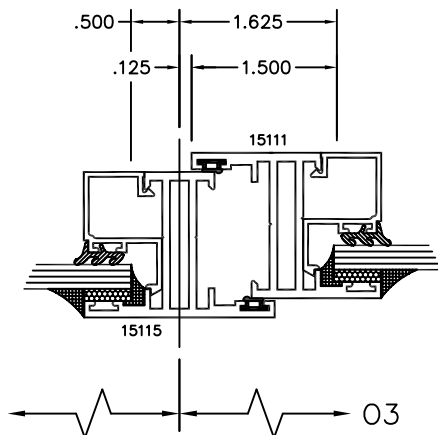
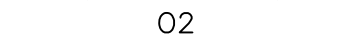
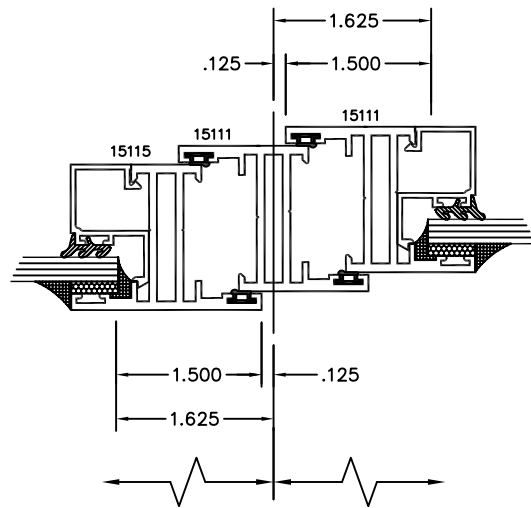
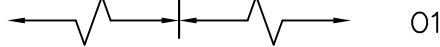
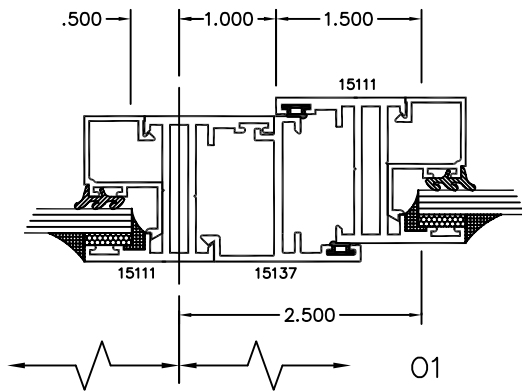

O VERTICAL INTERMEDIATES
PROJECT IN, PROJECT OUT
& COMBINATION

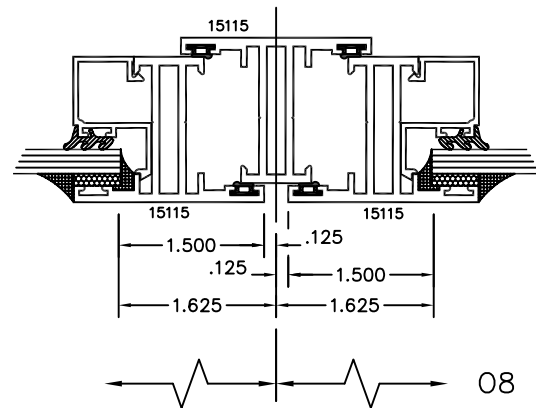
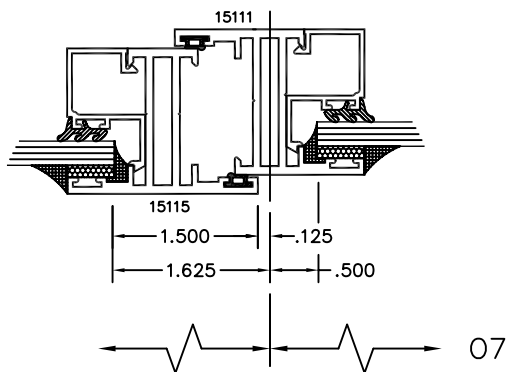
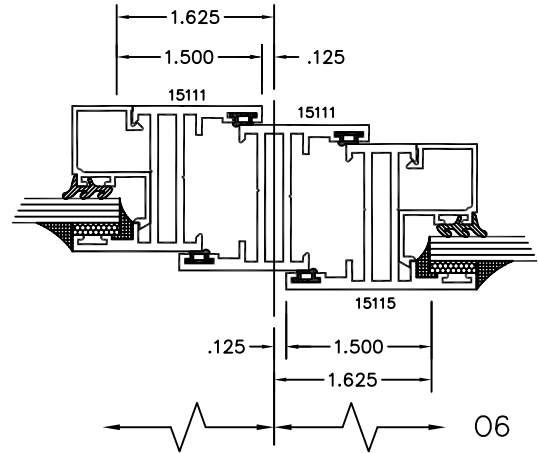
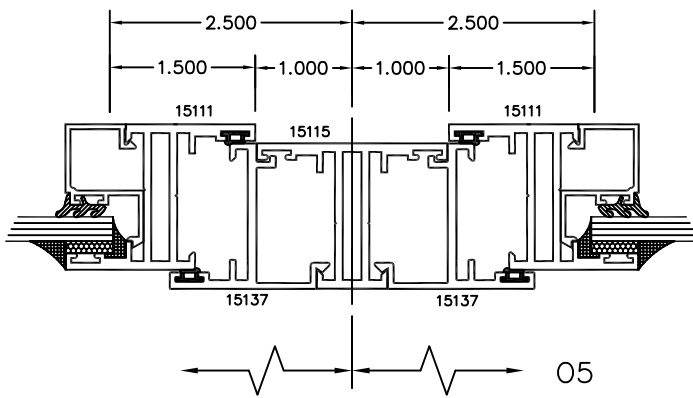

P HEAD AND JAMB COMPENSATING ARRANGEMENTS

Q SELF MULLING FRAME SECTIONS & MULLION

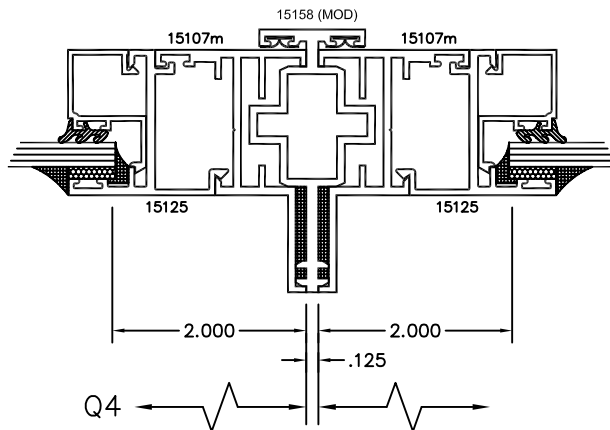
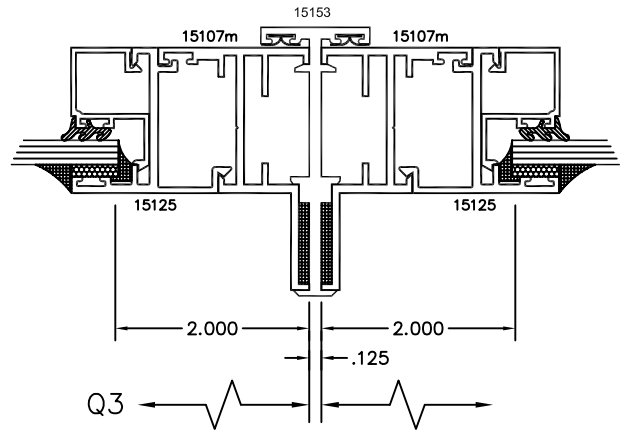
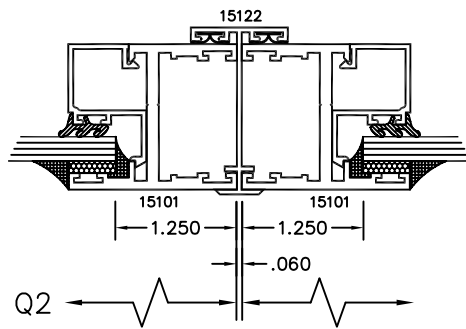
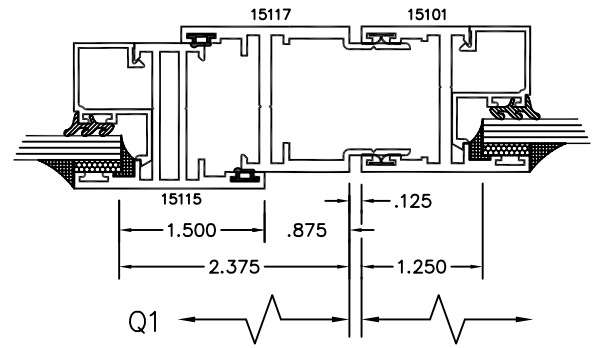
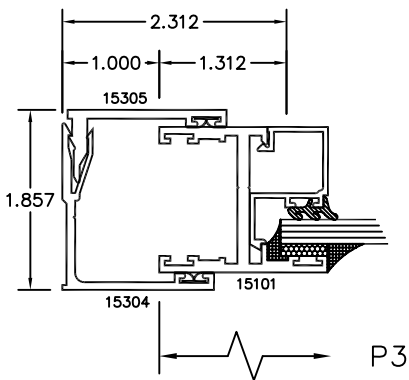
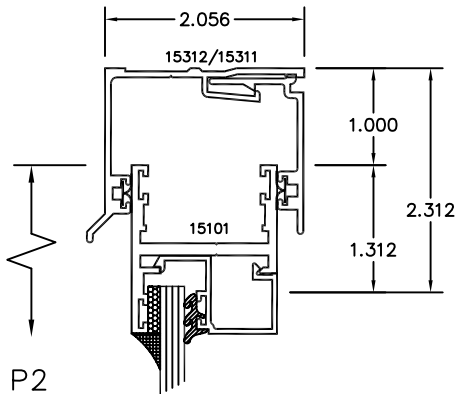
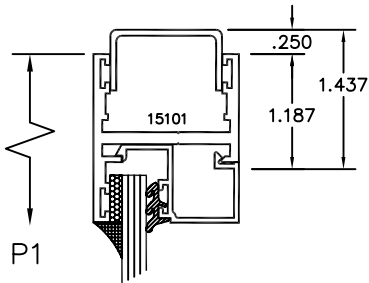

Q MULLIONS & CORNER MULLIONS

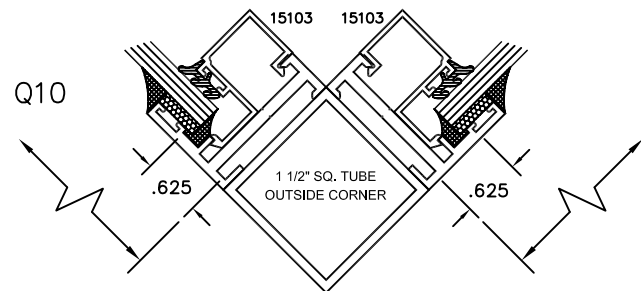
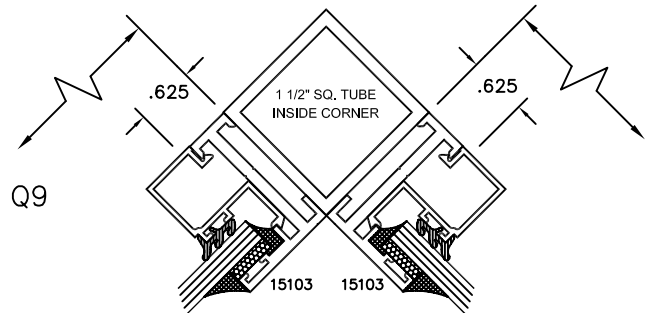
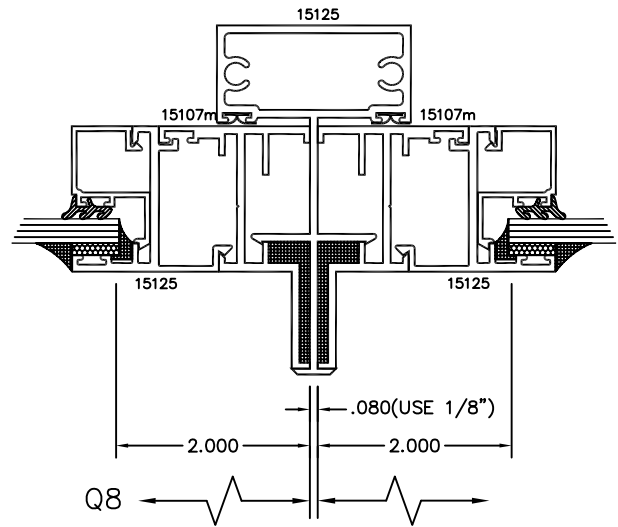
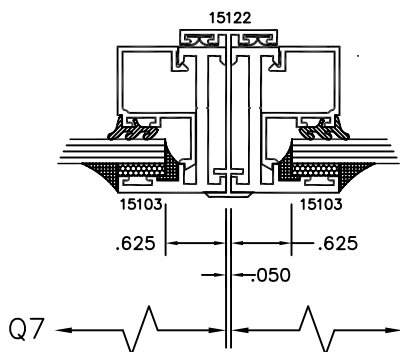
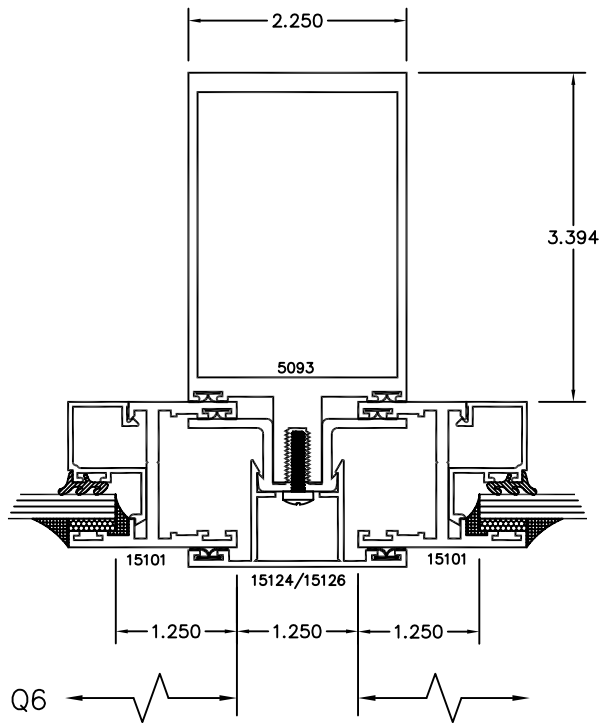
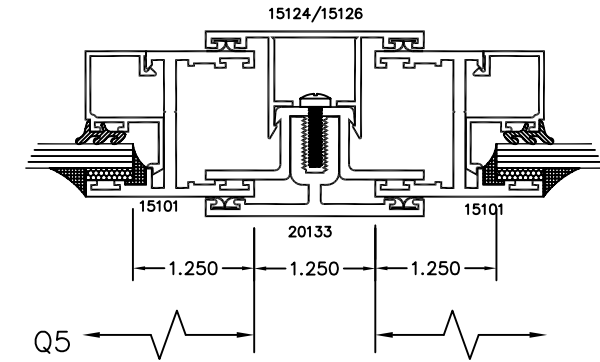

(R) SUB SILLS

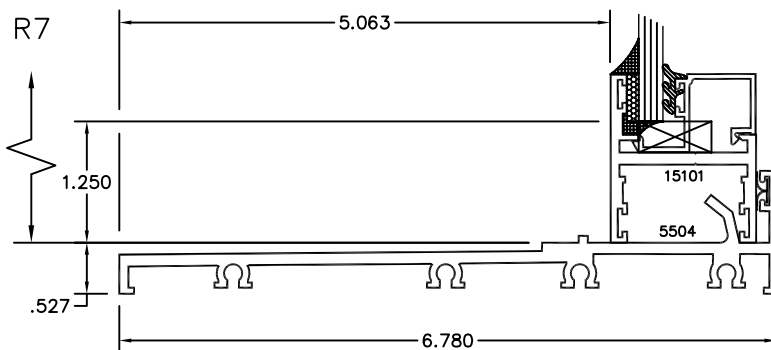
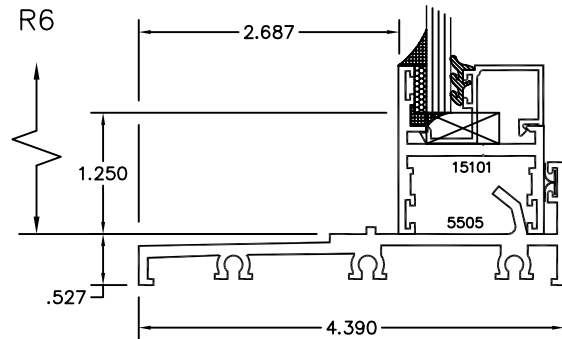
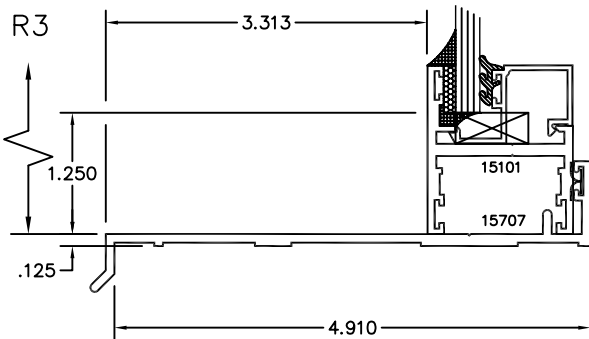
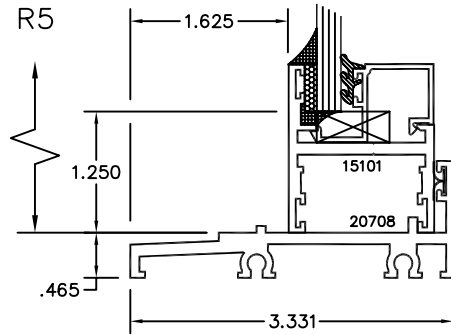
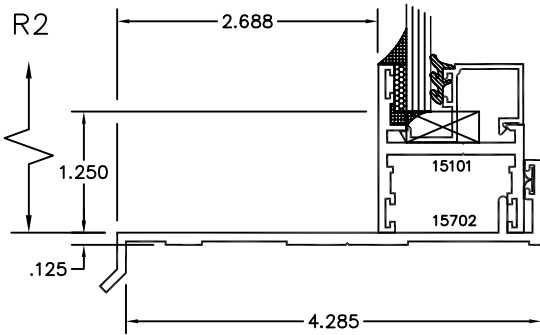
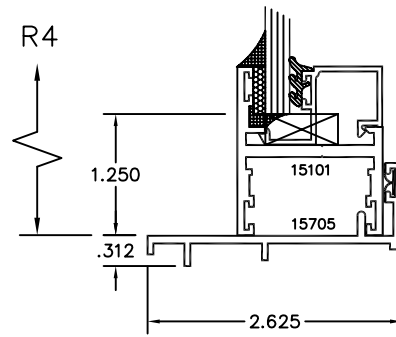
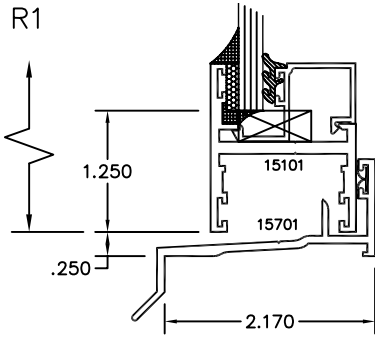

DEEP NAIL-ON FIN
PROJECT IN

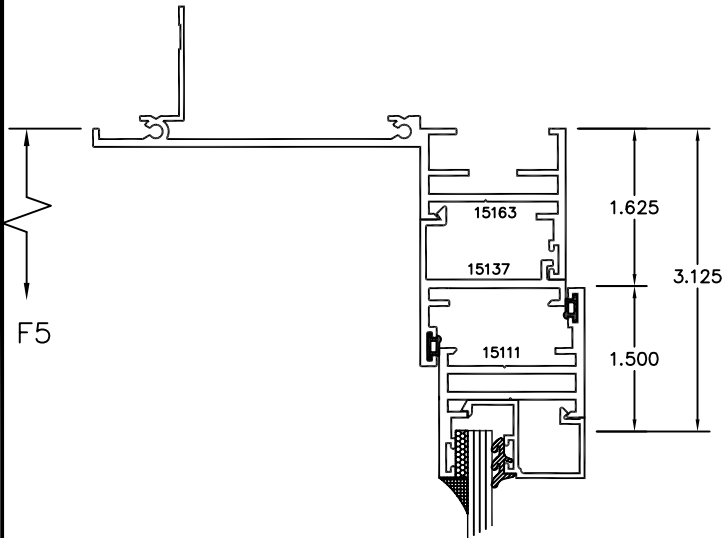

DEEP NAIL-ON FIN
PROJECT OUT

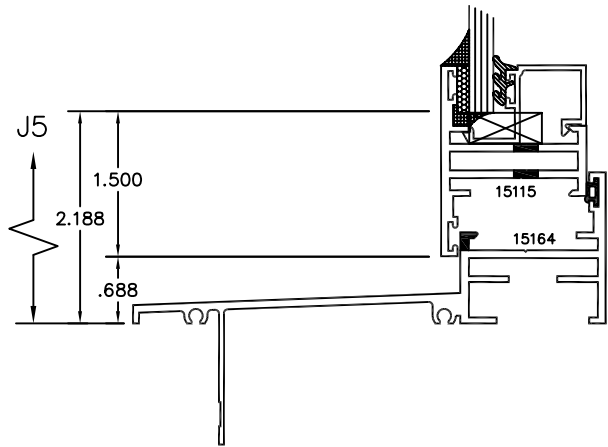
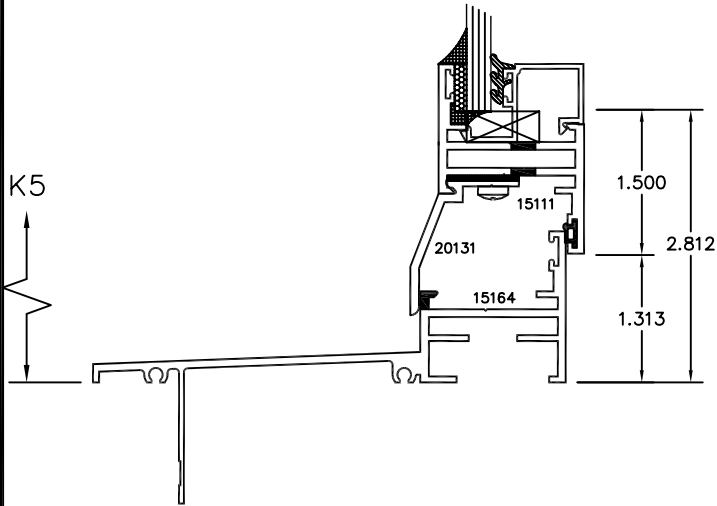
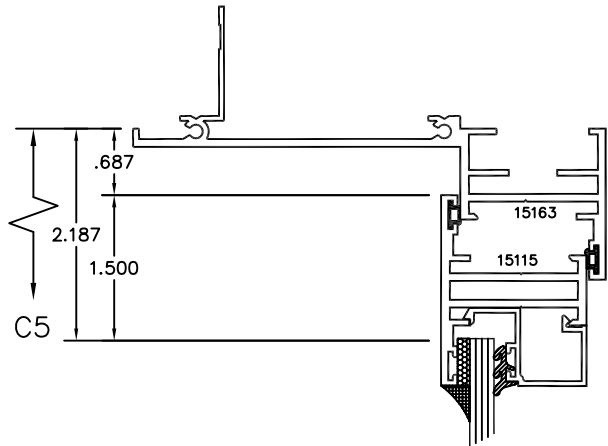

DEEP NAIL-ON FIN
FIXED

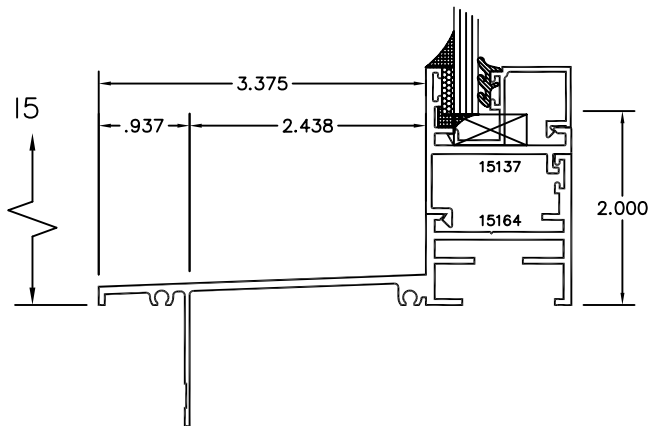
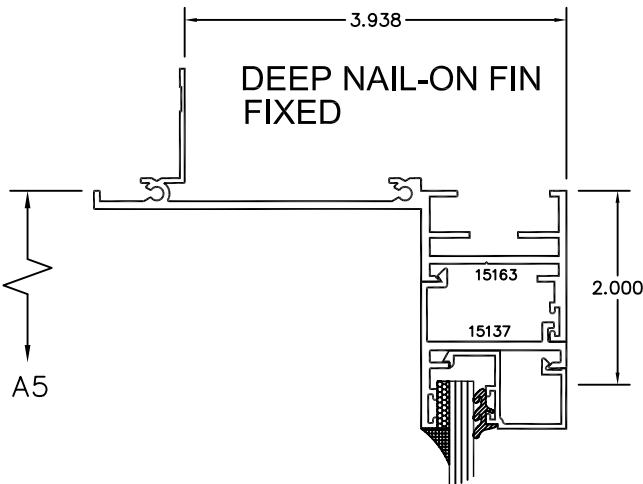

DEEP NAIL-ON FIN
JAMBS

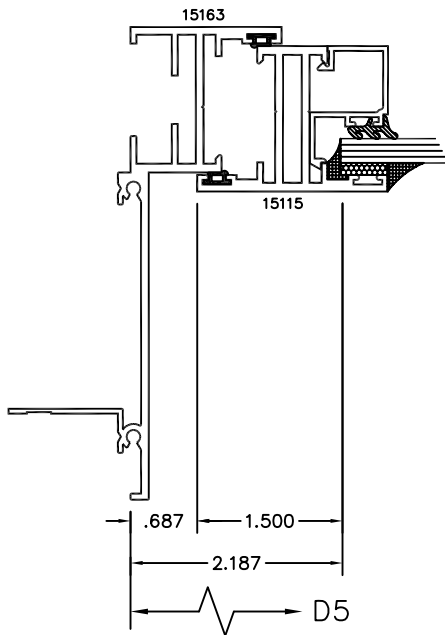
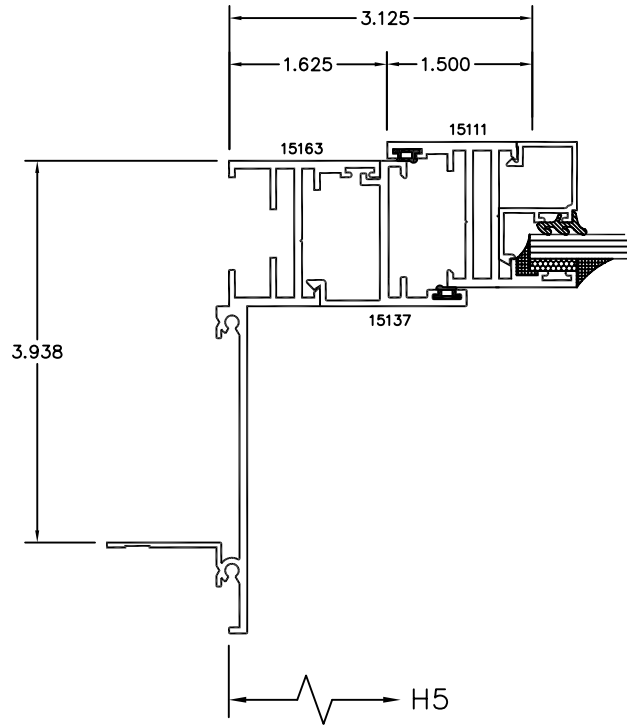
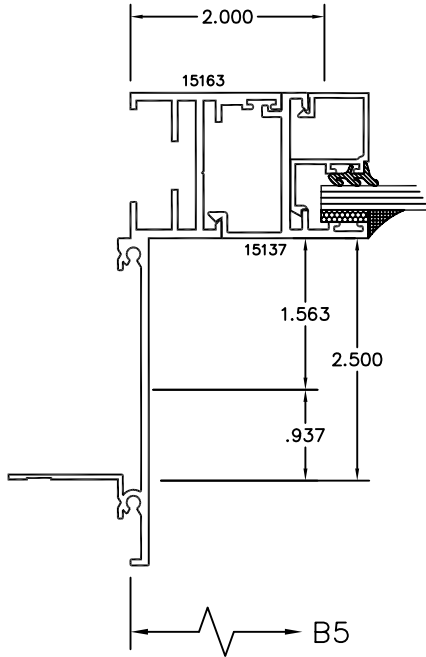

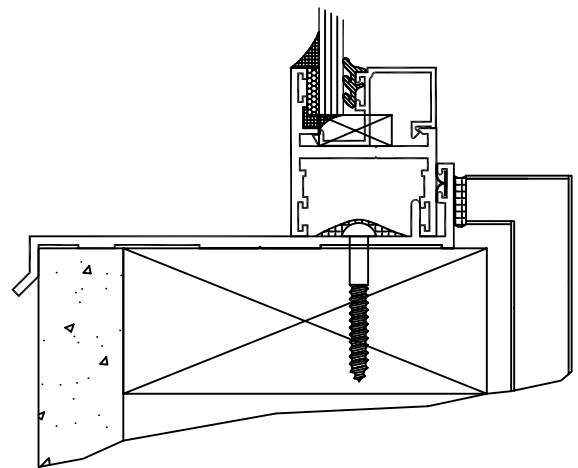
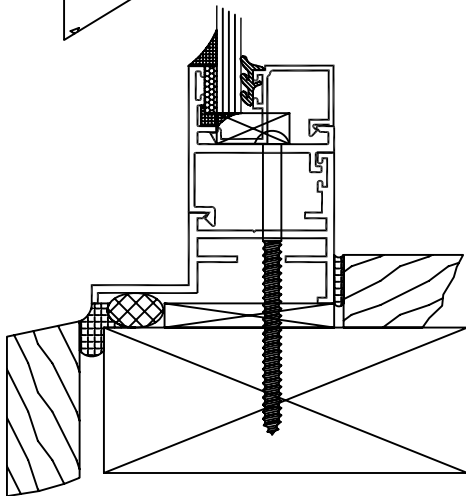
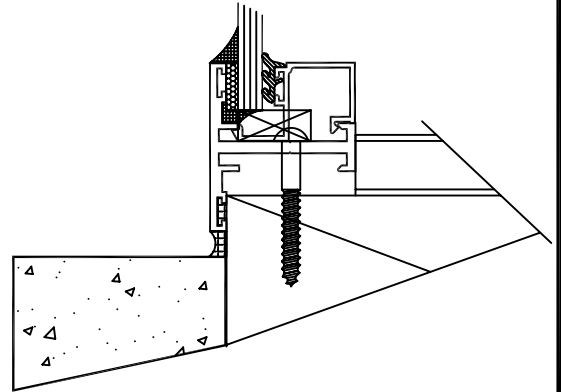
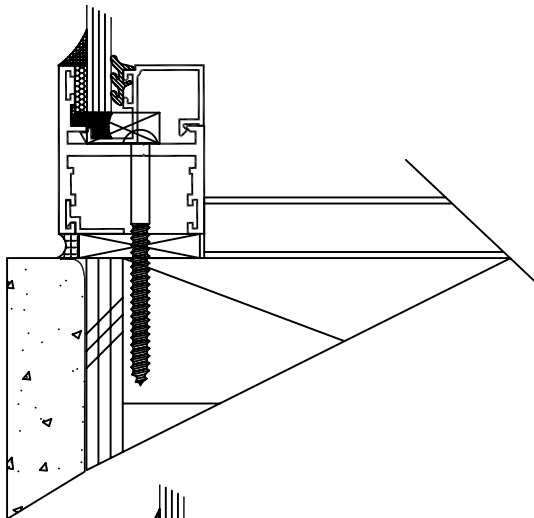
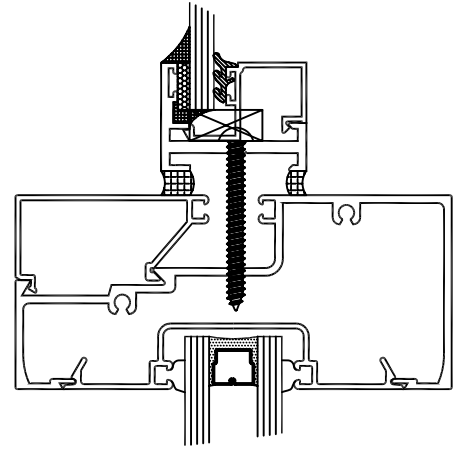
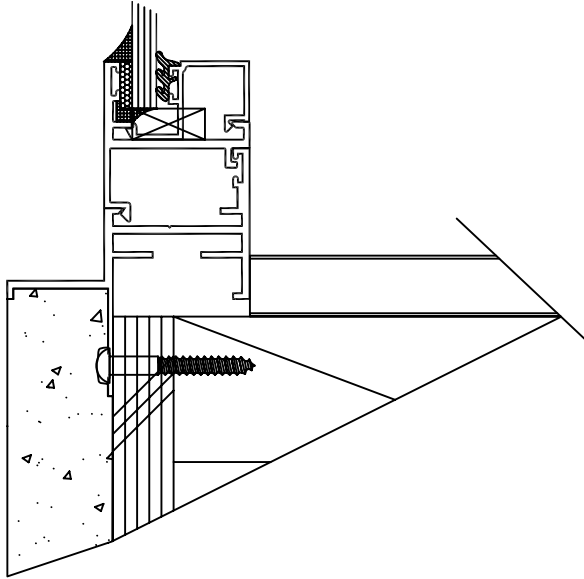

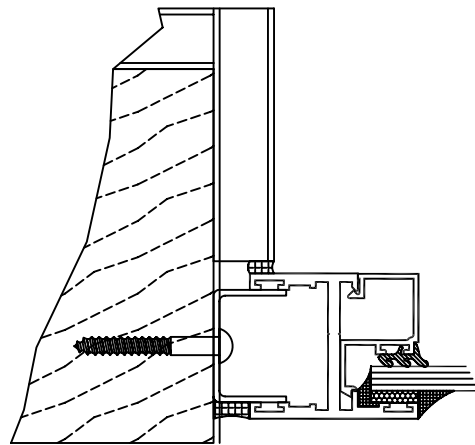
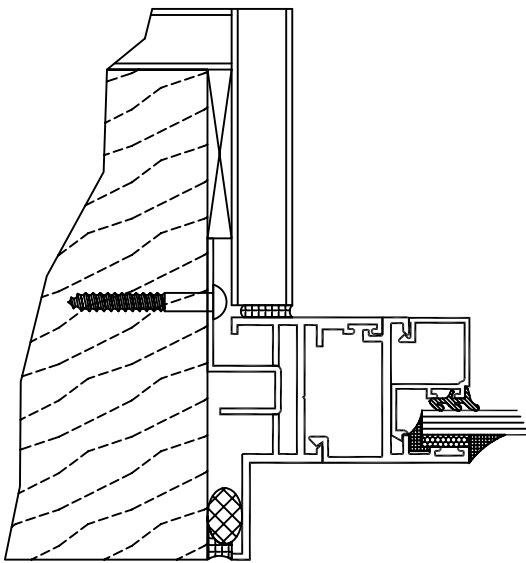
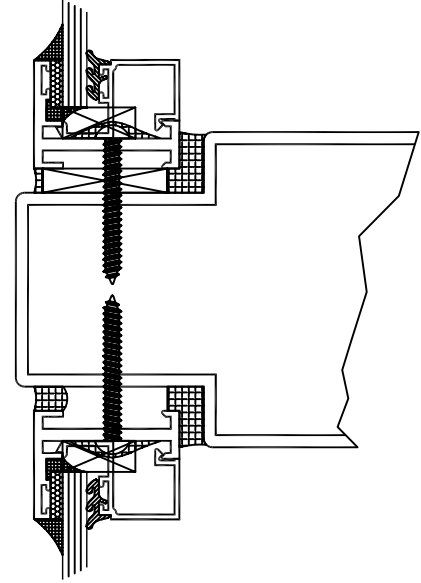
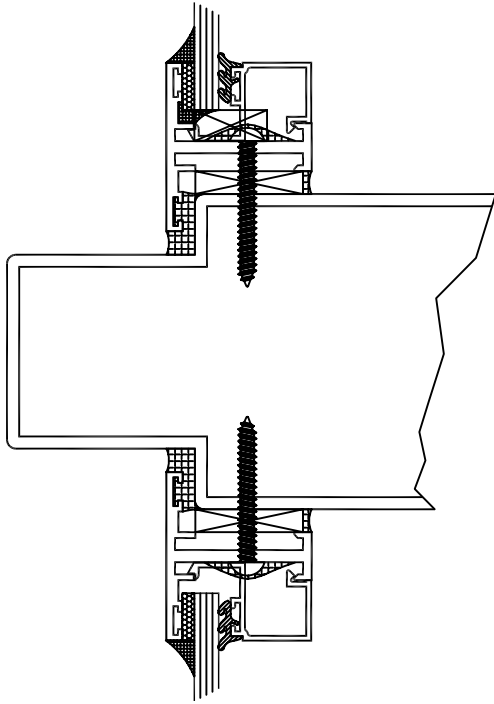

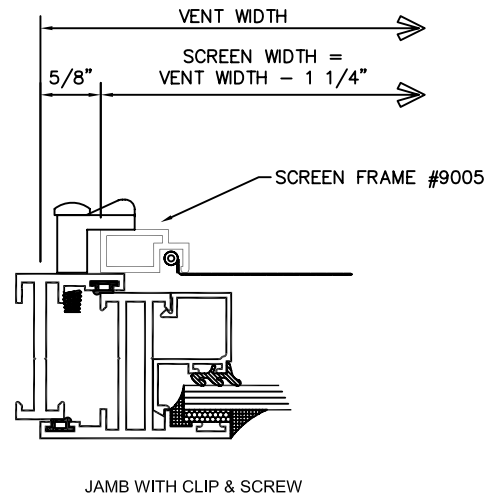
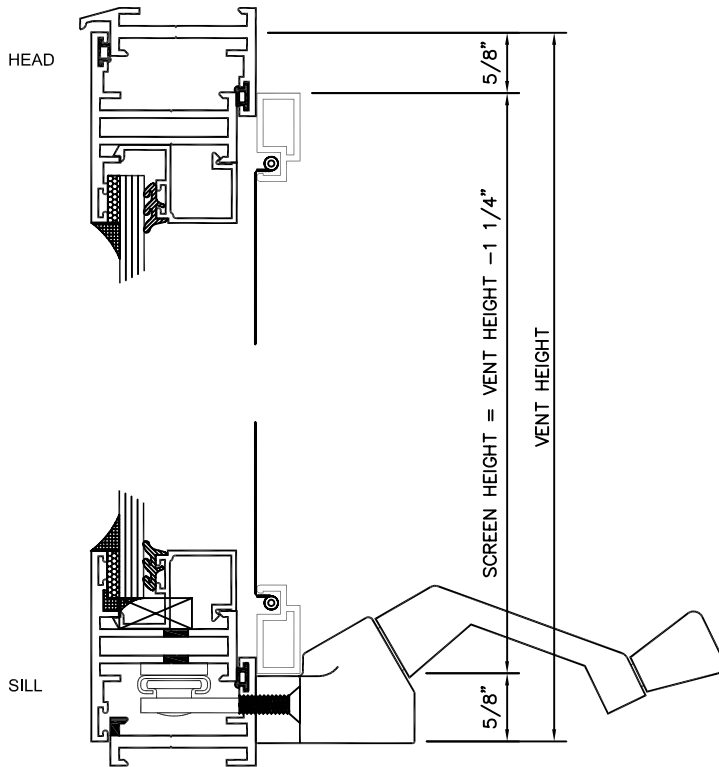

ROTO CASEMENT SCREEN

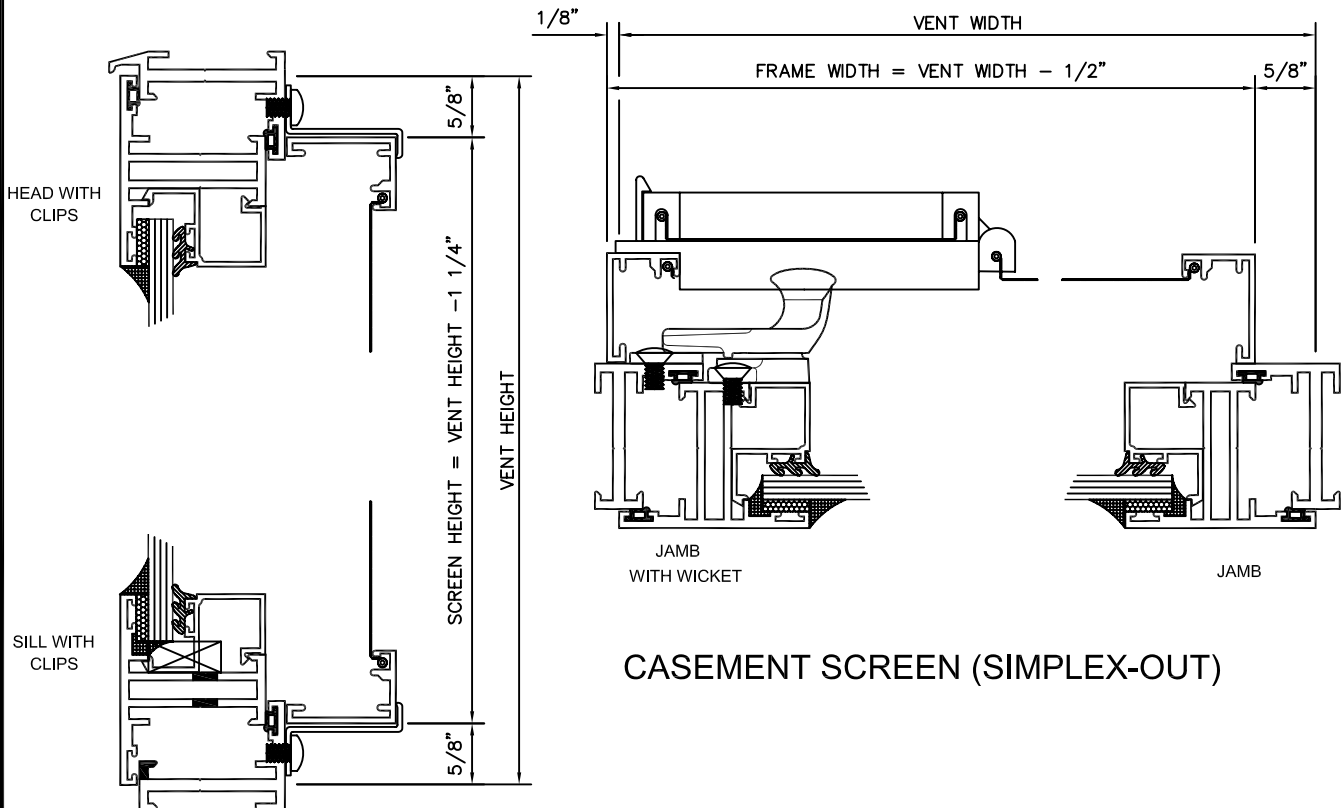

CASEMENT SCREEN (SIMPLEX-OUT)

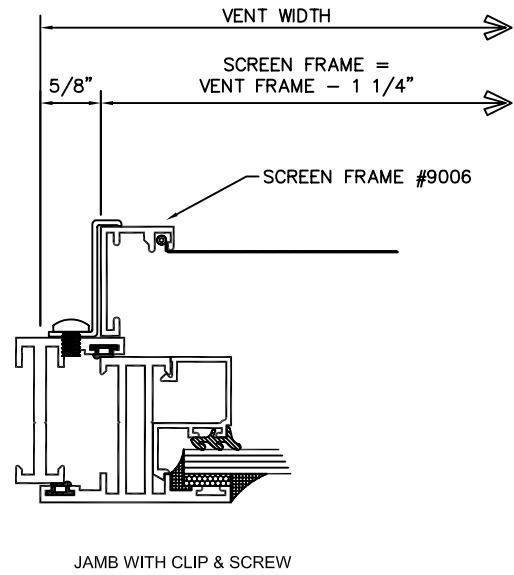
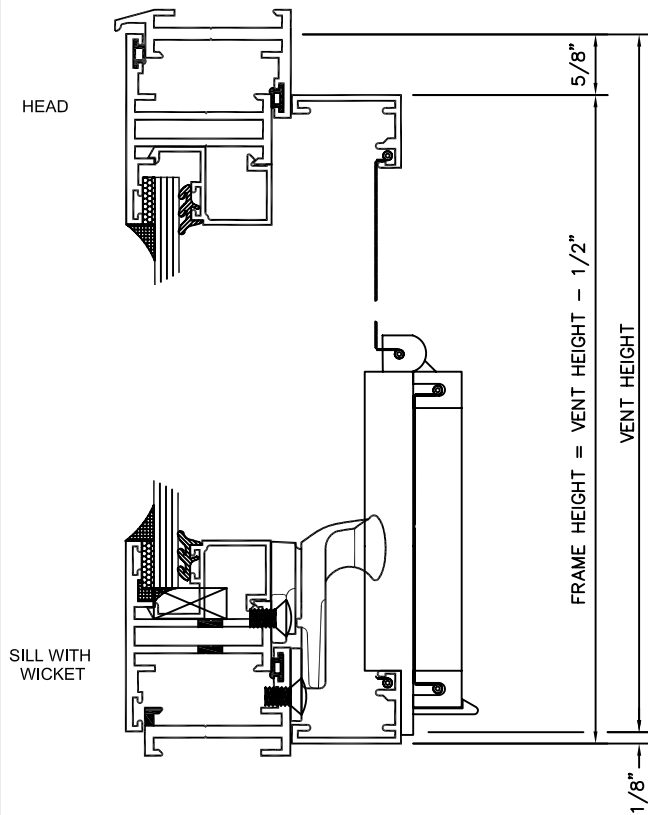

AWNING SCREEN (PROJECTED-OUT)

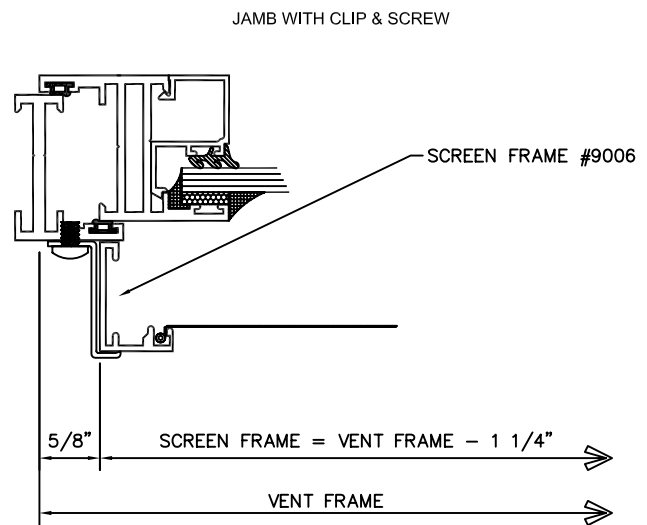
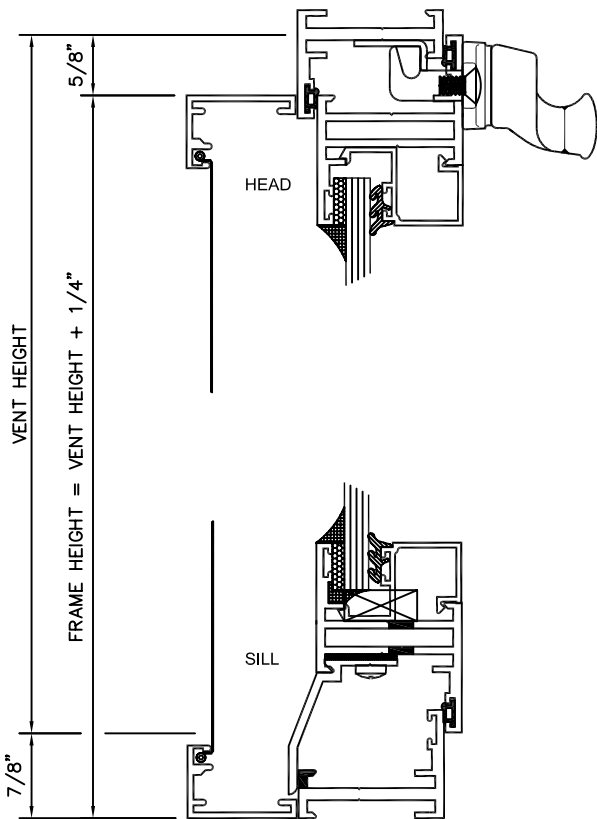

HOPPER SCREEN (PROJECTED-IN)

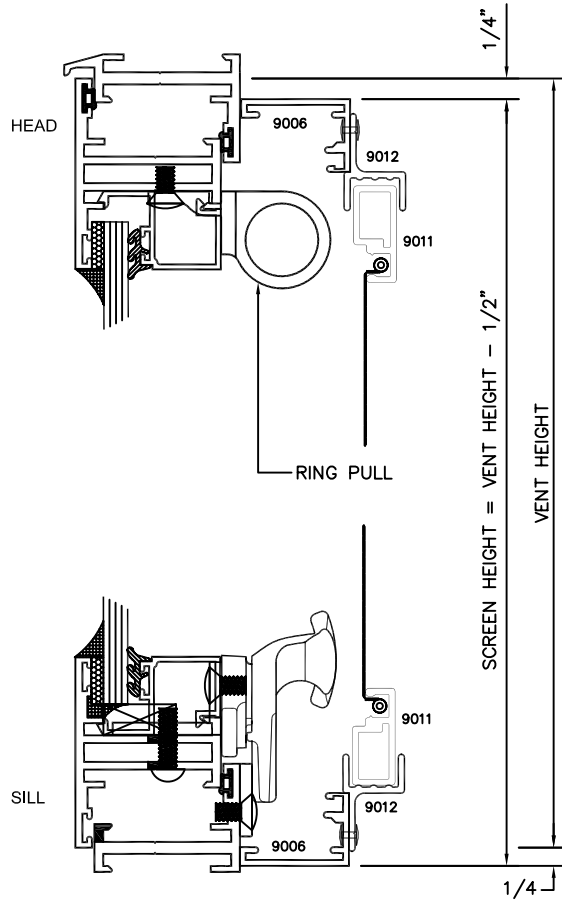

FULL HEIGHT SLIDING WICKET
SCREEN FOR POLE OPERATED
AWNING WINDOWS WITH RING PULL
(PROJECT OUT)

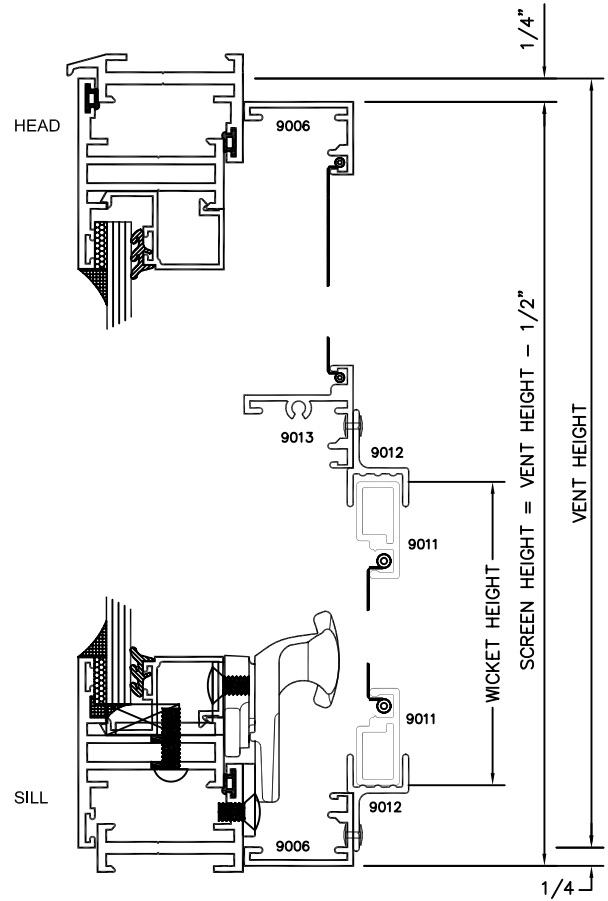

PARTIAL HEIGHT SLIDING WICKET
SCREEN FOR POLE OPERATED
AWNING WINDOWS WITHOUT RING
PULL (PROJECT OUT)

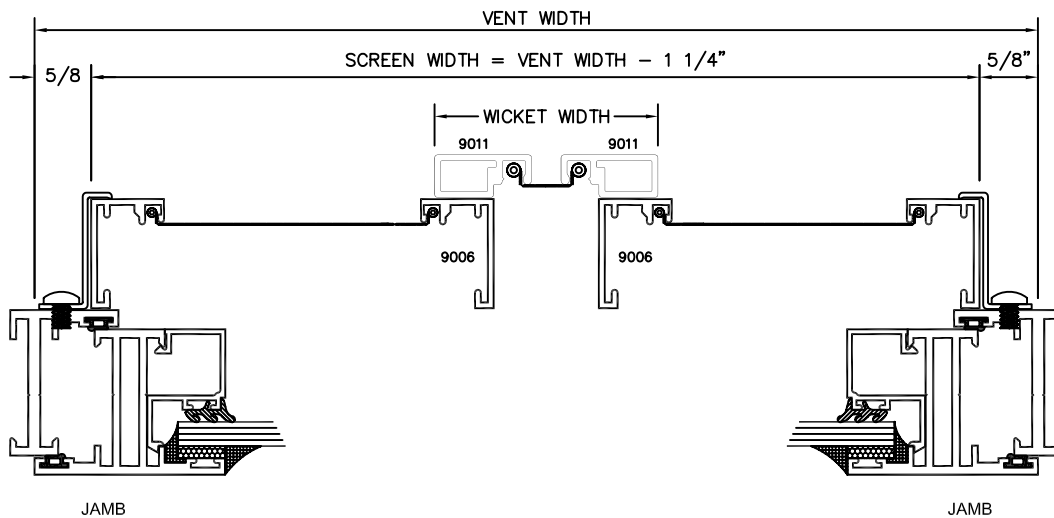

TORRANCE ALUMINUM

SERIES 1500 (C) & (HC) GLAZING OPTIONS

